



Growth of *Spirulina Maxima* in an Optimized Concentric Internal Tube Photobioreactor

Alfredo de Jesús, Martínez Roldán^{1,2*}, Brenda Paloma, Gómez Lozano³

¹CONACyT-TecNM/ Tecnológico Nacional de México/ IT de Durango. Master in Environmental Systems. Felipe Pescador 1830, Nueva Vizcaya, 34080 Durango, Dgo. México.

²Tecnológico Nacional de México/ IT de Durango. Master in Environmental Systems. Felipe Pescador 1830, Nueva Vizcaya, 34080 Durango, Dgo. México.

³Tecnológico Nacional de México/ IT de Durango. Department of Chemical and Biochemical Engineering. Felipe Pescador 1830, Nueva Vizcaya, 34080 Durango, Dgo. México.

*Corresponding author: Martínez-Roldan, CONACyT-TecNM/ Tecnológico Nacional de México/ IT de Durango. Master in Environmental Systems. Felipe Pescador 1830, Nueva Vizcaya, 34080 Durango, Dgo. México. Tel/Fax: +52-5533282875, E-mail: martinez@itdurango.edu.mx

Background: Microalgae have the potential to generate high-value products. The design of photobioreactors (PBRs), in which microalgae are cultured, is crucial because alterations in their configuration and operational conditions can affect the biomass production and productivity.

Objective: The objective of this study was to optimize the diameter of the internal tube of an airlift PBR and to characterize the growth of *Spirulina maxima* in an optimized design.

Material and Methods: *S. maxima* was cultured in a mineral medium without an organic carbon source. The PBR consisted of an acrylic cylinder with an operational volume of 7 L. Daily determinations of biomass (by filtration), chlorophyll, N-NO₃ and P-PO₄ (spectrophotometrically) were carried out.

Results: The use of a concentric tube with a diameter of 3 inches led to an increased biomass concentration of 1.14 ± 0.136 g.L⁻¹, allowing a global biomass productivity of 153 mg.L⁻¹.d⁻¹. The culture reached a volumetric consumption velocity of 27.34 ± 1.596 and 2.29 ± 0.353 mg.L⁻¹.d⁻¹ for N and P, respectively.

Conclusions: It was concluded that operational conditions must be specifically selected for each cultivated strain and that this configuration of airlift PBR can produce *Spirulina* biomass under laboratory conditions with a high biomass productivity.

Keywords: Biotechnology, Hydrodynamics, Microalgae, Photobioreactor, *Spirulina*.

1. Background

Microalgae are photosynthetic microorganisms that are capable of utilizing luminous energy and mineral nutrients for biomass generation. However, the term “microalga” does not have a valid taxonomic meaning as it includes organisms from diverse phylogenetic origins (1-3). Nevertheless, these microorganisms have metabolic similarities that allow them to be considered as a specific group. These characteristics include the presence of chlorophyll *a*, the capability to fix carbon

dioxide, and the absence of tissues (1). Their metabolic diversity suggests that microalgae could be used as a feasible source of different compounds and to develop biotechnological processes to produce high-value products, such as pigments, fatty acids, polyunsaturated fatty acids, proteins, antioxidants, and vitamins (2,4). However, regardless of the economic opportunity present in this group of microorganisms, there are only a few processes that can be scaled to the industrial level. This is because scaling up is difficult and many aspects

must be considered, such as operational conditions, biological characteristics, and contamination risks (2). Thus, it is necessary to develop technological tools to enable biomass production while reducing the potential challenges (5,6).

Photobioreactors (PBRs) are technical tools designed to cultivate photosynthetic microorganisms (5). The main aspect to be considered during their design is the necessity to supply light as a macronutrient for the growth of microalgae (5,7). The first PBRs were natural water bodies, without any instrumentation or control of the process, where algal blooms routinely occur. Subsequently, the process was improved and open systems were developed, making it possible to produce larger amounts of biomass; however, there was limited control over the operational conditions and variations in concentrations and composition of the biomass (5,7). After that, closed systems were developed with the objective of isolating the culture from the environment, which made it possible to reduce the contamination risk. The use of PBRs allows the manipulation of operational conditions and the possibility to optimize these parameters. The control of this process made it possible to achieve higher biomass productivities and to obtain biomass with specific characteristics and constant composition (5,6).

There are many diverse configurations of PBR, including flat panels, tubular, bubbled columns, annular systems, and special configurations (torus, thin-layer, etc.), and the movement of the liquid can be carried out by the employment of pumps or airlift systems (pneumatically mixed) (5,8–10). Each design has advantages and disadvantages that must be considered during the selection process (5). Given the variety of configurations, a specific configuration must be selected according to the requirements of the strains to be cultured, the culturing conditions, and the main objective of the process (5,6).

Specifically, for vertical tubular systems (columns), there are many diverse configurations, such as the bubbled column (the simplest one), in which mixing is carried out by the insufflation of air from the bottom of the PBR (5,11). This configuration is useful for the production of shear-stress-sensitive strains. In addition, there are columns with airlift operations. In these configurations, the addition of an immovable dispositive metal sheet, concentric tube, or external mixing arm allows a specific flow pattern to improve the hydrodynamic

characteristics of the system. Nevertheless, the shear stress also increases, thereby hindering the culture of shear-stress sensitive strains, including filamentous strains, or requiring the operational conditions to be modified to diminish the metabolic effects (11).

Many configurations have been studied for the cultivation of *Spirulina*, and many authors have demonstrated that it is possible to produce *Spirulina* biomass using tubular, flat panel, helicoidally tubular, or even open systems (10,12,13).

The biomass production of *Spirulina* is not strongly affected by light limitation as the photosynthetic production of oxygen does not change at biomass concentrations lower than 5–7 g.L⁻¹, even at low levels of light (500 $\mu\text{E}\cdot\text{m}^{-2}\cdot\text{s}^{-1}$) (10,14). Nevertheless, there are other parameters that increase the biomass production by mixing (5). The mixing can be improved using different strategies, such as increasing the air inflow and adding static mixers; nevertheless, it is necessary to consider the increase in shear stress caused by high insufflation flows (11). In the air-lift column, the use of a concentric tube (riser) when the air is bubbled can increase the biomass concentration because the development of a mixing pattern diminishes the stratification, avoids the autoshading effect, and allows the removal of the produced oxygen in a more efficient way compared with the bubbled columns (12,14). Nevertheless, the dimensions of the riser and air insufflation must be selected for each microalgae strain.

2. Objective

The goal of this study was to design and use the best concentric internal tube for the production of *Spirulina maxima* in an airlift PBR and to characterize the growth and nutrient consumption in the selected configuration.

3. Materials and Methods

3.1. Strain, Culturing Medium, and Experimental Conditions

S. maxima was provided by Prof. Hugo V. Perales Vela, Facultad de Estudios Superiores, Universidad Nacional Autónoma de México. Cyanobacterium was cultured in a mineral medium without an organic carbon source (15). Growth experiments were performed with an initial chlorophyll concentration of 2–3.0 mg.L⁻¹ and were illuminated with eight lamps (36 W) of cold white light reaching an irradiation of 250 $\mu\text{E}\cdot\text{m}^{-2}\cdot\text{s}^{-1}$ over

the entire surface of the PBR. The temperature was maintained at 22 ± 2 °C, and the growth was monitored daily.

3.2. Photobioreactor

The PBR consisted of an acrylic cylinder with a thickness of 6 mm, with an external diameter of 15.24 cm (6 in), height of 60 cm, and an operational volume of 7 L. Other characteristics of the PBR are listed in **Table 1**. Air was supplied by a Hailza® ACO-328 air compressor with variable flow. Internal concentric tubes (ICTs) were constructed using polyvinyl chloride (PVC) according to their specific characteristics.

3.3. Analytical Determinations

Mixing time: The mixing time was determined using an acid tracer (concentrated hydrogen chloride (HCl)) and by measuring the change in pH. The pH was measured using a pH meter (Thermo Scientific®). Mixing was considered complete when the pH variation was less than 5%.

Dry weight: The dry weight of the biomass was measured by filtering the culture according to Equation (16). A glass-fiber filter (Whatman®) was dried at 105 °C for 1 h, weighed, and the culture was filtered, washed with distilled water, and dried again at the same temperature until a constant weight was achieved.

Total chlorophyll: Pigments were extracted with methanol and quantified spectrophotometrically according to Equation (3). The culture was filtered through filter paper and washed with distilled water. A volume of

methanol was then added, and the mixture was placed into a block heater (Felisa®) and incubated at 100 °C for 5 min. The absorbance at 669 and 750 nm was measured using methanol as a blank in a spectrophotometer (ThermoScientific UV/BIS Genesys 10S®).

N-NO₃ quantification: N-NO₃ was quantified in the cell-free supernatant using a modified resorcinol technique (17). Briefly, 2 mL of 2% resorcinol solution was added to the sample along with sulfuric acid, and the mixture was incubated in the dark for 30 min. The solution was brought to 7.5 mL with distilled water and was allowed to cool down at room temperature. Subsequently, the absorbance at 505 nm was measured using a spectrophotometer (ThermoScientific UV/BIS Genesys 10S®).

P-PO₄ quantification: Quantification was carried out using a modified phosphomolybdate method according to (17). Trichloroacetic acid (0.5 N) was added to the cell-free supernatant, along with a 16% ammonium molybdate and 5% ferrous sulfate. The samples were incubated in the dark for 15 min, and the absorbance was measured at 660 nm using a spectrophotometer (ThermoScientific UV/BIS Genesys 10S®).

3.4. Statistical Analysis

Experiments were performed with at least three independent replicates. The mean \pm standard error of the mean (SEM) is shown in the tables and graphs. A two-way analysis of variance (ANOVA) was performed at a significance level of 5%. Subsequently, Bonferroni analysis was performed using GraphPad Prism 5.0®.

Table 1. Specifications of the photobioreactor and concentric tubes.

Photobioreactor		Concentric tubes			
Characteristic		Characteristic	2 inches	3 inches	4 inches
Total Volume	9 L	External diameter	5.08 cm	7.62 cm	10.16 cm
Operational Volume	7 L	Internal diameter	4.48 cm	7.02 cm	9.56 cm
Total height	60 cm	Total height	40.00 cm	40.00 cm	40.00 cm
Liquid height	48 cm	Wings dimensions (length height):	4.21 x 2.00 cm	2.94 x 2.00 cm	1.67 x 2.00 cm
External Diameter	15.24 cm	Dimensions of the bottom brackets	2.00 x 3.00 cm	2.00 x 3.00 cm	2.00 x 3.00 cm
Internal Diameter	13.64 cm	Thickness of the PVC	3.00 mm	3.00 mm	3.00 mm
Thickness	0.80 cm	Riser transversal area (A_R)	15.76 cm ²	38.70 cm ²	71.78 cm ²
		Downcomer transversal are: (A_D)	130.36 cm ²	107.42 cm ²	74.34 cm ²
		A_D/A_R ratio	8.3	2.8	1.1

4. Results

4.1. Design and Construction of Internal Concentric Tubes

Static concentric tubes were designed considering the height of the liquid inside the PBR and the air flow that can be used for the growth of different microalgal and cyanobacterial strains. Tubes with 2, 3, and 4 inches diameter were selected to construct the static mixers as they allow sufficient transversal areas in the space, downcomer, and riser. The ratio between the riser and downcomer must be carefully selected to ensure intense mixing with a low shear stress (11,18). The operational parameters included in the design of the ICT were as follows: at an operational volume of 7 L, the liquid height was 48 cm, the external diameter of the PBR was 15.24 cm, and the internal diameter of the acrylic tube was 13.64 cm (Table 1). The concentric tubes were constructed with sanitary PVC with a thickness of 3 mm, according to the general scheme shown in Figure 1. Four wings of PVC were added to the central tube in both the upper and bottom sections to reach a diameter of 13.54 cm (Table 1). This permitted the position of the ICT to be fixed inside the PBR without the risk of movement. In the bottom part, the majority of the tube was removed, leaving only four brackets with a width of 2 cm. This allowed a homogeneous flux of liquid from the downcomer to the riser sections. Considering a liquid height of 48 cm, the height of the ICT was fixed at 40 cm to maintain sufficient liquid volume in the upper part to continue the flow pattern regardless of

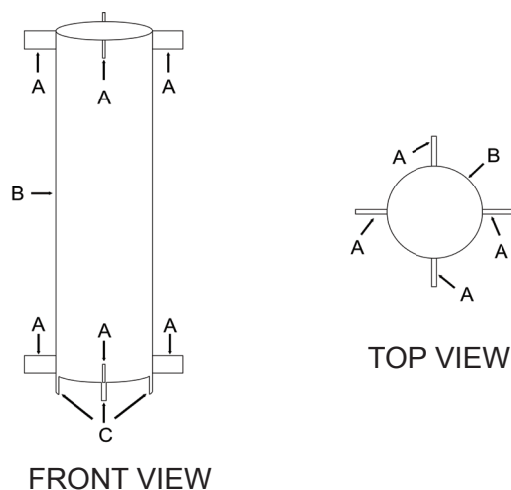

Figure 1. General scheme of the concentric tube. A) Wings. B) Tube. C) Bottom brackets.

the daily evaporation and sampling. All the wings were constructed with the same height (2.00 cm) (Table 1), but the length varied according to the diameter of the ICT. The lengths of the wings were 1.67, 2.50, and 4.21 cm for the tubes with 4, 3, and 2 inches of diameter, respectively, leading to a total diameter of the static mixer of 13.50 cm.

4.2. Determination of the Mixing Time

The mixing time was quantified using the culture medium and two different air flows for each ICT. The mixing time values formed two groups (Fig. 2); in one group, there were bubbled columns and the airlift with the 2-inch internal tube, which had no significant differences between them ($p > 0.05$). These experiments reached mixing times of 27.6 ± 1.32 and 26.4 ± 1.34 seconds for the bubbled column and 2-inch internal tube, respectively, when they were insufflated with $2 \text{ L}\cdot\text{min}^{-1}$ of air. Additionally, very similar values were obtained with $12 \text{ L}\cdot\text{min}^{-1}$ of air. In the second group were the 3- and 4-inch of diameter tubes, which were not significantly different at $2 \text{ L}\cdot\text{min}^{-1}$ ($p < 0.05$); however, at the highest air flow ($12 \text{ L}\cdot\text{min}^{-1}$ of air), the values were 13.3 ± 1.04 and 10.1 ± 0.78 seconds for the 3- and 4-inch tubes, respectively. Initially, it was proposed that the growth of *S. maxima* at the highest air flow should be evaluated, but the hydrodynamic shear stress is too high and breaks the cells. Therefore, we chose to use half of the studied interval, and the air flow was fixed at $3.5 \text{ L}\cdot\text{min}^{-1}$ (0.50 vvm). This value was selected because many studies have reported excellent behavior

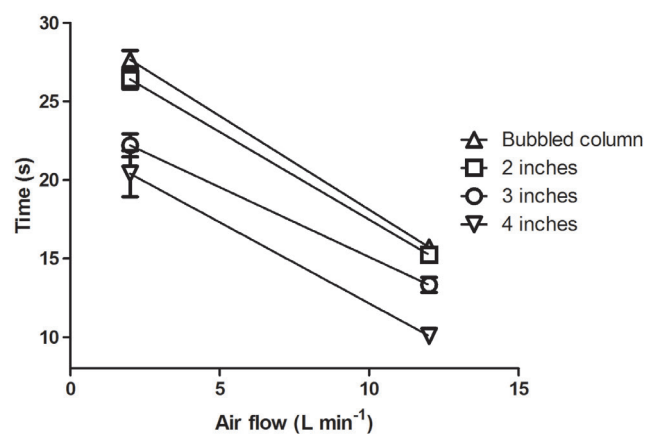

Figure 2. Mixing times for the different concentric tubes.

of *Spirulina* cultures when the mixing time was less than 90 s (19); an aeration of 3.5 L.min⁻¹ was used because the value of mixing time under this condition was smaller than the suggested value.

4.3. Effect of the Diameter of Internal Tube on *S. Maxima* Biomass Production

Figure 3A shows the effect of different diameters of the concentric tubes on biomass concentration (as dry weight), with an insufflation of 0.5 vvm (3.5 L.min⁻¹). The values obtained at the beginning and end of the experiments were not significantly different ($p > 0.05$); nevertheless, the maximum value obtained using an ICT of 3-inches diameter was significantly different from the values of the other experimental conditions ($p < 0.01$). The experiments began with biomass concentrations of 0.060 and 0.160 g.L⁻¹, with no significant differences between them ($p > 0.05$). Over the next 6 d of culture, all conditions increased their dry weight concentration (DW), reaching values of 0.995 ± 0.062 , 1.130 ± 0.059 , and 0.86 ± 0.46 g.L⁻¹ for the cultures with an ICT of 2,

3, and 4 inches on day 6, respectively. The maximum biomass concentration was observed in the culture with the 3-inch ICT: 1.325 ± 0.093 g.L⁻¹ on day 4. This value was 27% and 43% higher than the values obtained for cultures with ICT diameters of 2 and 4 inches, respectively.

With respect to the chlorophyll *a* (Chl_a) concentrations, the behavior was slightly different; all experiments began with concentrations ranging from 2.5–3 mg.L⁻¹ of Chl_a, and its concentration increased until reaching the highest values at days 6 and 7 (**Fig. 3B**). The experiment using an ICT of 4 inches yielded the highest final chlorophyll concentration of 21.72 ± 3.68 mg.L⁻¹. However, the highest value during the entire experiment was obtained by the culture with an internal tube of 3 inches in diameter on day 6 of culture, but this was significantly reduced by day 7. The chlorophyll concentrations were different across conditions throughout the experiment ($p < 0.05$), but all values of chlorophyll concentrations on day 6 ranged from 17.48–21.47 mg.L⁻¹, with variations smaller than 15%. These small differences suggest

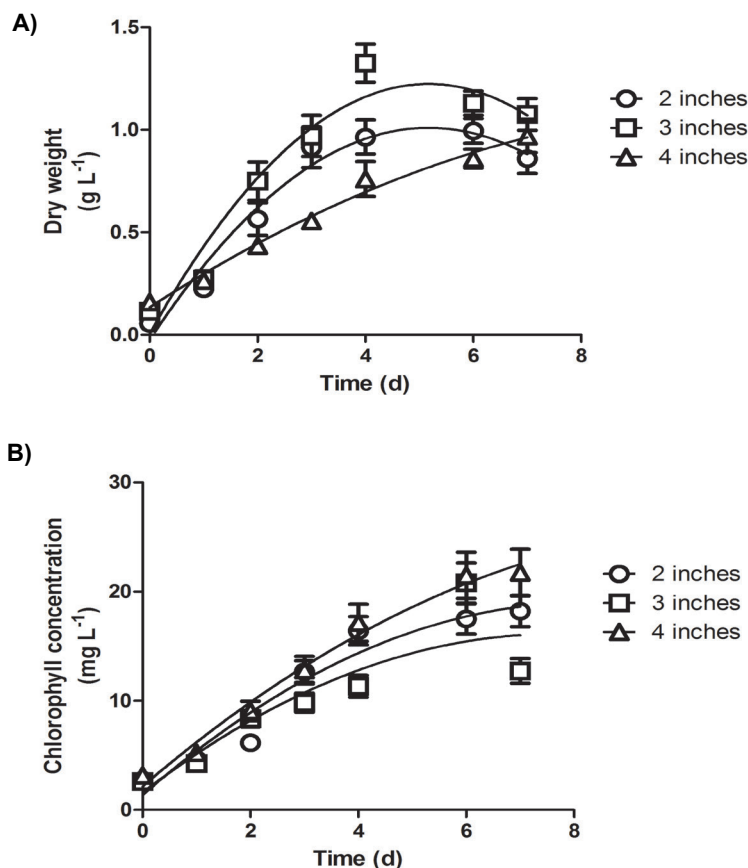

Figure 3. **A)** DW concentration for the different concentric tubes. **B)** Total chlorophyll concentration using different concentric tubes.

good mixing in the three experimental conditions, with no significant differences in either DW or chlorophyll concentration.

4.4. Characterization of *S. Maxima* Growth in Airlift PBR with a 3-Inch Concentric Tube

ICT with a 3-inch diameter produced a higher biomass concentration and was subsequently used to characterize the growth and nutrient consumption of *S. maxima* over the course of 8 d. This was carried out by determining the daily concentrations of DW, chlorophyll *a*, N-NO₃, and P-PO₄ daily. Experiments were carried out at 0.3 vvm (2.1 L.min⁻¹), given that Banerjee *et al.* (2020) recommended that this insufflation ratio is optimal, regardless of the operational condition selected. If shear stress is reduced (19), *S. maxima* growth is improved because cellular rupture and culture death are avoided (12).

The biomass concentration (**Fig. 4A**) presented an initial value of 0.10 ± 0.014 g.L⁻¹ and started to grow

rapidly until day 7, when the biomass concentration was 1.17 ± 0.020 g.L⁻¹. At day 7, the stationary phase was reached, and the biomass did not increase on day 8, yielding a final biomass concentration of 1.14 ± 0.136 g.L⁻¹ at the end of the experiment (day 8). The final value was not significantly different from the value reached on day 7 ($p > 0.05$), demonstrating a true stationary phase. The maximum biomass concentration in this culture is similar to that reported by other authors, who reported maximum values ranging from 1–2 g.L⁻¹ for cultures grown in mineral medium with no organic carbon source (12,20–22) quality, or production cost could significantly impact the Spirulina industry. The objectives of this paper were defined as to contribute to this goal. Spirulina biomass productivity was investigated through medium choice. A modified Zarrouk's medium was selected as it gave higher final dry weights and longer sustained growth than Hiri's and Jourdan's media. Then, in order to reduce Spirulina

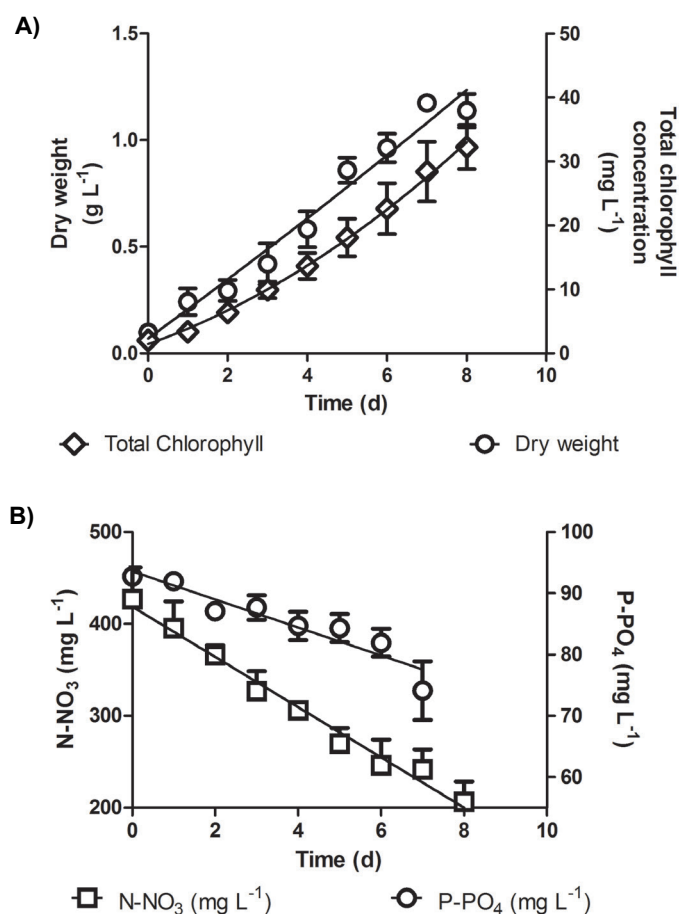

Figure 4. A) Biomass and total chlorophyll concentrations in the *Spirulina maxima* culture. B) N-NO₃ and P-PO₄ concentrations in the *Spirulina maxima* culture.

production cost, modified Zarrouk's medium was rationalized by testing different dilutions. It was found that modified Zarrouk's medium could be diluted up to five times without impacting the growth rates in a 28-days batch cultivation. Higher dry weights were even observed after 21 days of batch cultivation (1.21 g^{-1} for 20%-modified Zarrouk's medium in comparison to 0.84 g^{-1} for modified Zarrouk's medium. Nevertheless, it is important to note that our experiments started with a biomass concentration of $100 \text{ mg} \cdot \text{L}^{-1}$ and were carried out for only 8 d. This is important because the majority of the reports reached a final concentration of $1 \text{ g} \cdot \text{L}^{-1}$ over longer cultivation times (up to 15 d of culture) or with higher initial biomass concentrations (up to $0.35 \text{ g} \cdot \text{L}^{-1}$) (20).

The biomass concentration on day 7 was $1.14 \pm 0.136 \text{ g} \cdot \text{L}^{-1}$ and the biomass accumulation was calculated based on the initial value ($\sim 0.10 \text{ g} \cdot \text{L}^{-1}$), reaching a value of $1.07 \text{ g} \cdot \text{L}^{-1}$. Considering the biomass accumulation and the days of culture, it was possible to determine that the global biomass productivity was $153 \text{ mg} \cdot \text{L}^{-1} \cdot \text{d}^{-1}$. This value is higher than those reported by other authors, who failed to surpass $130 \text{ mg} \cdot \text{L}^{-1} \cdot \text{d}^{-1}$ (12,20,21) quality, or production cost could significantly impact the *Spirulina* industry. The objectives of this paper were defined as to contribute to this goal. *Spirulina* biomass productivity was investigated through medium choice. A modified Zarrouk's medium was selected as it gave higher final dry weights and longer sustained growth than Hiri's and Jourdan's media. Then, in order to reduce *Spirulina* production cost, modified Zarrouk's medium was rationalized by testing different dilutions. It was found that modified Zarrouk's medium could be diluted up to five times without impacting the growth rates in a 28-days batch cultivation. Higher dry weights were even observed after 21 days of batch cultivation (1.21 g^{-1} for 20%-modified Zarrouk's medium in comparison to 0.84 g^{-1} for modified Zarrouk's medium. This value is higher because *S. maxima* grows faster and only 7 d are required to reach the maximum biomass concentration, while previous studies needed to perform 15 d of culture to reach the same concentration (20,22). Additionally, the initial biomass concentration is important because the majority of other reports started with a higher biomass concentration ($\sim 300 \text{ mg} \cdot \text{L}^{-1}$), which considerably reduced the biomass productivity values (22).

Chlorophyll concentration was proportional to biomass

concentration (**Fig. 4B**). The cultures started with a *Chla* concentration of $2.05 \pm 0.091 \text{ mg} \cdot \text{L}^{-1}$ and the concentration increased until it reached a maximum value of $32.25 \pm 3.43 \text{ mg} \cdot \text{L}^{-1}$ on day 8. *Chla* accumulation was calculated to be $30.2 \text{ mg} \cdot \text{L}^{-1}$ proportional to biomass concentration. Calculation of the specific *Chla* content was possible due to similar behaviors of the DW and *Chla* concentrations; the value was $26.53 \pm 1.484 \text{ mg} \cdot \text{Chla} \cdot \text{g}_{\text{ps}}^{-1}$. This is similar to the reported values for different microalgal species growing in mineral media with high concentrations of nitrogen and phosphorus (16,17,23,24).

The concentrations of nitrogen and phosphorus showed significant reductions over the entire experiment; the concentrations decreased linearly, indicating consumption. Nitrogen had an initial concentration of $426 \pm 34.515 \text{ mg} \cdot \text{L}^{-1}$ and this value diminished until it reached a final concentration of $206.44 \pm 21.982 \text{ mg} \cdot \text{L}^{-1}$. This reduction represented 51.6% of the initial nitrogen content in the medium. The consumption of nitrogen and the linear behavior allowed the volumetric consumption rate to be calculated as $27.34 \pm 1.596 \text{ mg} \cdot \text{L}^{-1} \cdot \text{d}^{-1}$; this value is similar to those reported for microalgae and cyanobacteria growing in mineral media in different PBR configurations (16,17,23,24). In many studies, the fast consumption of nitrogen from the culture medium by *Spirulina* is correlated with the need for high levels of this nutrient for cellular protein synthesis. This is because the amount of protein in *Spirulina* is very high (up to 70%), and in a medium without amino acids (as used by Zarrouk), all proteins must be synthesized *de novo* (15,20,21).

Phosphate was also consumed very quickly but at a lower rate than nitrogen. P-PO_4 had an initial concentration of $92.75 \pm 1.694 \text{ mg} \cdot \text{L}^{-1}$ and reached a final concentration of $64.80 \pm 13.025 \text{ mg} \cdot \text{L}^{-1}$, which represented a 30% consumption of the initial amount. The consumption of P-PO_4 was also linear (similar to nitrogen consumption) during the first 7 d of culture. The volumetric consumption rate was $2.29 \pm 0.353 \text{ mg} \cdot \text{L}^{-1} \cdot \text{d}^{-1}$.

5. Discussion

There are many obstacles in obtaining microalgal cultures with very high biomass concentrations. One of them is optimizing the light supply – if the biomass concentration is very high the auto-shading effect appears; nevertheless, the growth diminution by the

auto-shading phenomenon is significant only when the biomass concentration is higher than 5 g.L^{-1} or when the light supply is lower than $500 \mu\text{E.m}^{-2}\text{s}^{-1}$ (10,14,25). In this work, the differences observed between the different PBR configurations can be attributed only to the presence of concentric tubes and their diameters, because the biomass concentration did not exceed 2 g.L^{-1} , regardless of whether the illumination was high and sufficient to reach this concentration (10).

The dimensions of the brackets in the bottom permitted the liquid to enter from the downcomer to the riser, without any obstacles and significant modifications of the flow pattern. Selecting the diameter of the concentric tube is challenging because many dimensions have been published; however, some authors agree that the most important parameter is not the size, but rather that the ratio between the transversal area of both the sections, raiser and downcomer, which is the limiting factor. (5,11,26).

Some authors have proposed employing airlift systems for the cultivation of *Spirulina*; however, PBR configurations, experimental conditions, and DW values remain very diverse. Oncel and Sukan (2008) suggested analyzing the ratio between the transversal areas of the riser and the downcomer (A_D/A_R ratio) to ensure optimal distribution and mixing (12). In their investigation, they utilized an airlift PBR with an A_D/A_R ratio close to 1 and obtained biomass concentrations similar to those obtained in this work. However, other authors have proposed an A_D/A_R ratio ranging from 1.5–3, and they assured that these values lead to optimal flow patterns and mass transfer, regardless of the cultured microalgal strain (11,27,28). Considering the diameters of the PBR and ICT, the A_D/A_R ratio can be estimated. The A_D/A_R ratios were 8.3, 2.8, and 1.1 for tubes with 2, 3, and 4 inches of diameter, respectively. These values explain the fact that the maximum DW value was achieved in the culture with an ICT of 3 inches, given that it meets the values for the A_D/A_R ratio suggested in previous studies (27).

In the selected configuration, *S. maxima* growth was fast, reaching values higher than those reported for this strain in other PBR configurations, which was due to the good mixing achieved without shear stress in this configuration. *Spirulina* is a filamentous cyanobacterium, and the hydrodynamic characteristics inside the reactor are very important because an increase in shear stress can cause cellular death and reductions in biomass concentrations

(11). In addition, the chlorophyll concentration was high, causing an increase in the levels of this pigment, which may be due to both the optimal culture conditions and sufficient light supplied (12). Despite the light used ($250 \mu\text{E.m}^{-2}\text{s}^{-1}$ around the PBR), the maximum concentration of biomass was high, owing to the indoor culturing conditions.

The rapid consumption of phosphorus and nitrogen was due to the fact that carbon is the principal macronutrient required by *S. maxima* for the production of biomass, as is the case for all photosynthetic microorganisms (1). The consumption of nitrogen was higher than $25 \text{ mg.L}^{-1}\text{d}^{-1}$, which corresponds to the absorption of this nutrient by highly active microalgal cultures. Normally, nitrogen is eliminated from the culturing media at rates ranging from $20\text{--}35 \text{ mg.L}^{-1}\text{d}^{-1}$ (14,23,29).

These values indicate accelerated growth under the selected conditions and make it possible to ensure that no light limitation occurred during *Spirulina* growth. For phosphorus, a special phenomenon is observed; this nutrient is removed from the culturing medium very quickly, regardless of its initial concentration. This is called luxurious consumption. This type of consumption causes an almost constant consumption rate of approximately $1\text{--}3 \text{ mg.L}^{-1}\text{d}^{-1}$, regardless of the strain, medium, or even the PBR configuration employed (23,30). The phosphorus inside the cell is accumulated in polyphosphate bodies that can be observed by electronic microscopy, which can be used when the concentration in the medium is low, without any need for metabolic changes (17,23).

6. Conclusions

The design and construction of static mixers in an airlift PBR must be done with consideration to the engineering, biotechnological, and biological parameters to ensure optimal growth of the selected strain. For flagellated microalgae and filamentous cyanobacteria, the use of operational conditions in which the mixing time is short (ensuring good mass transfer) is not ideal. This was observed in cultures grown with an insufflation of 0.5 vvm (3.5 L.min^{-1}), where *S. maxima* grew but did not reach higher biomass concentrations that were achieved in cultures with an insufflation of 0.3 vvm (2.1 L.min^{-1}). As such, a specific analysis based on the characteristics of the strain to be cultured is necessary to find an equilibrium between the optimal growth and good mass transfer (mixing) conditions.

The PBR and the configuration employed here allowed us to obtain high biomass and chlorophyll concentrations, even with moderate light (250 $\mu\text{E}\cdot\text{m}^{-2}\cdot\text{s}^{-1}$ around PBR). However, it is necessary to study the effects of increasing light flux and modified operational conditions (e.g., nutrient concentration, amount of inoculum, etc.) to further optimize the process and achieve higher biomass concentrations.

Acknowledgements

The authors would like to thank the Department of Chemical and Biochemical Engineering from TecNM/IT Durango for their help and financial support.

References

- Barsanti L, Gualtieri P. Algae: Anatomy, Biochemistry, and Biotechnology. 2nd Editio. CRC Pres. 2014. 301 pp.
- Martínez-Roldán AJ, Ibarra-Berumen J. Employment of Wastewater to Produce Microalgal Biomass as a Biorefinery Concept. In: Microalgae biotechnology for development of biofuel and wastewater treatment. Springer Singapore; 2019. p. 487-504. doi:10.1007/978-981-13-2264-8_19
- Vonshak A. *Spirulina Platensis Arthrospira*: Physiology, Cell-biology and Biotechnology. 1st ed. 1997. 119 pp.
- Draaisma RB, Wijffels RH, Slegers P, Brentner LB, Roy A, Barbosa MJ. Food Commodities from Microalgae. *Curr Opin Biotechnol*. 2013;24(2):169-177. doi:10.1016/j.copbio.2012.09.012
- Martínez-Roldán AJ, Cañizares-Villanueva RO. Photobioreactors: Improving the Biomass Productivity. In: Torres-Bustillos L, editor. Microalgae and other phototrophic bacteria: culture, processing, recovery and new products. 1st ed. Nova Science Publishers; 2015.p.145-170.
- Zittelli GC, Rodolfi L, Tredici MR. Industrial Production of Microalgal Cell-Mass and Secondary Products - Species of High Potential: Mass Cultivation of *Nannochloropsis* in Closed Systems. In: Richmond A, editor. Handbook of microalgal culture: biotechnology and applied phycology. Oxford, UK: Blackwell Publishing Ltd; 2007.p.298-303. doi:10.1002/9780470995280.ch16
- Park JBK, Craggs RJ. Wastewater Treatment and Algal Production in High Rate Algal Ponds with Carbon Dioxide Addition. *Water Sci Technol*. 2010;61(3):633-639. doi:10.2166/wst.2010.951
- Osuna Salazar NK, Pacheco Fernández MA, Gómez Lozano BP, Martínez-Roldán AJ. Design and Construction of a Bubbled Column for Microalgae Culture. 3rd Biotechnol Summit 2016, Ciudad Obregón, Son. Mex. 24-28 Oct. 2016. <https://www.cabdirect.org/cabdirect/abstract/20173097456>
- Torzillo G, Giannelli L, Martínez-Roldán AJ, Verdone N, De Filippis P, Scarsella M, et al. Microalgae Culturing in Thin-layer Photobioreactors. *Chem Eng Trans*.2010;20:265-270. doi:10.3303/CET1020045
- Qiang H, Richmond A. Productivity and Photosynthetic Efficiency of *Spirulina platensis* as Affected by Light Intensity, Algal Density and Rate of Mixing in a Flat Plate Photobioreactor. *J Appl Phycol*. 1996;8(2):139-145. doi:10.1007/BF02186317
- Vega-Estrada J, Montes-Horcasitas MC, Domínguez-Bocanegra AR, Cañizares-Villanueva RO. *Haematococcus pluvialis* Cultivation in Split-Cylinder Internal-Loop Airlift Photobioreactor Under Aeration Conditions Avoiding Cell Damage. *Appl Microbiol Biotechnol*. 2005;68:31-35. doi:10.1007/s00253-004-1863-4
- Oncel S, Sukan FV. Comparison of Two Different Pneumatically Mixed Column Photobioreactors for the Cultivation of *Arthrospira platensis* (*Spirulina platensis*). *Bioresour Technol*. 2008;99(11):4755-4760. doi:10.1016/j.biortech.2007.09.068
- Sili C, Torzillo G, Vonshak A. *Arthrospira* (*Spirulina*). In: Whitton B, editor. Ecology of Cyanobacteria II: Their diversity in space and time. *Springer Sci Business Media*. 2012.p.677-705. doi:10.1007/978-94-007-3855-3_25
- Heredia JCR, García AN, Ruiz-Marin A, Lopez YC, Rivero J del CZL and JCS. Effect of Hydrodynamic Conditions of Photobioreactors on Lipids Productivity in Microalgae. In: Microalgal Biotechnol Intechopen, 2018. doi:10.5772/intechopen.74134
- Zarrouk C. Contribution to the Cyanophyceae Study: Influence Various Physical and Chemical Factors on Growth and Photosynthesis of *Spirulina maxima*. University of Paris. 1966.
- Martínez-Roldán AJ, Perales-Vela HV, Cañizares-Villanueva RO, Torzillo G. Physiological Response of *Nannochloropsis* sp. to Saline Stress in Laboratory Batch Cultures. *J Appl Phycol*. 2014;26(1):115-121. doi:10.1007/s10811-013-0060-1
- Martínez-Roldán AJ, Gómez-Lozano BP, Díaz-Ramírez MA, Ruiz-García MA. Diseño y Construcción de un Fotobiorreactor Tipo Flat Panel para la Producción de Biomasa *Stigeoclonium nanum*. In: Diseminación de la Investigación en la Educación Superior: Celaya 2019. Academia Journals; 2019. p. 2116–2120.
- Fernandes BD, Mota A, Ferreira A, Dragone G, Teixeira JA, Vicente AA. Characterization of Split Cylinder Airlift Photobioreactors for Efficient Microalgae Cultivation. *Chem Eng Sci*. 2014;117:445-454. doi:10.1016/j.ces.2014.06.043
- Banerjee S, Dasgupta S, Das D, Atta A. Influence of Photobioreactor Configuration on Microalgal Biomass Production. *Bioprocess Biosyst Eng*. 2020;43(8):1487–1497. doi:10.1007/s00449-020-02342-4
- Delrue F, Alaux E, Moudjaoui L, Gaignard C, Fleury G, Perilhou A, et al. Optimization of *Arthrospira platensis* (*Spirulina*) Growth: From Laboratory Scale to Pilot Scale. *Fermentation*. 2017;3:59. doi:10.3390/fermentation3040059
- Soni RA, Sudhakar K, Rana RS. Comparative Study on the Growth performance of *Spirulina platensis* on Modifying Culture Media. *Energy Reports*. 2019;5:327–336. doi:10.1016/j.egy.2019.02.009
- Torres L, Lopez Y, Gomez-y-Gomez Y, Bautista E, Corzo L. Production and Broad Characterization of a *Spirulina platensis* Dry Powder Grown in Bubbled Columns. *J Adv Microbiol*. 2018;9:1-16. doi:10.9734/JAMB/2018/39995
- Franco Martínez ML, Rodríguez Rosales MDJ, Moreno Medina CU, Martínez-Roldán AJ. Tolerance and Nutrients Consumption of *Chlorella vulgaris* Growing in Mineral Medium and Real Wastewater Under Laboratory Conditions. *Open Agric*. 2017;2(1):394-400. doi:10.1515/opag-2017-0042
- Martínez-Roldán AJ, Cañizares-Villanueva RO. Effect of the Nitrogen-Source Modification and CO₂-Addition on Growth and Lipids Composition in *Nannochloropsis* sp. In: Jan M,

- Kazik P, editors. *Nannochloropsis*: Biology, biotechnological potential and challenges. *Nova Publisher*. 2017.p.45-74.
25. Costa JAV, Freitas BCB, Rosa GM, Moraes L, Morais MG, Mitchell BG. Operational and Economic Aspects of *Spirulina*-based Biorefinery. *Bioresour Technol*. 2019;**292**:121946. doi:10.1016/j.biortech.2019.121946
 26. Fernandes BD, Mota A, Teixeira JA, Vicente AA. Continuous Cultivation of Photosynthetic Microorganisms: Approaches, Applications and Future Trends. *Biotechnol Adv*. 2015;**33**(6):1228-1245. doi:10.1016/j.biotechadv.2015.03.004
 27. Monksit S, Powtongsook S, Pavasant P. Comparison Between Airlift Photobioreactor and Bubble Column for *Skeletonema costatum* Cultivation. *Eng J*. 2011;**15**(4):53-64. doi:10.4186/ej.2011.15.4.53
 28. Pawar SB. Process Engineering Aspects of Vertical Column Photobioreactors for Mass Production of Microalgae. *ChemBioEng Rev*. 2016;**3**(3):101-115. doi:10.1002/cben.201600003
 29. Pelizer LH, Danesi EDG, Rangel C de O, Sassano CEN, Carvalho JCM, Sato S, et al. Influence of Inoculum Age and Concentration in *Spirulina platensis* Cultivation. *J Food Eng*. 2003;**56**(4):371–375. doi:10.1016/S0260-8774(02)00209-1
 30. Cade-Menun BJ, Paytan A. Nutrient Temperature and Light Stress Alter Phosphorus and Carbon Forms in Culture-Grown Algae. *Mar Chem*. 2010;**121**(1):27-36. doi:10.1016/j.marchem.2010.03.002