

Agrobacterium*-mediated transformation of cotton (*Gossypium hirsutum*) using a synthetic *cry1Ab* gene for enhanced resistance against *Heliothis armigera

Masoud Tohidfar*, Behzad Ghareyazie, Mojgan Mosavi, Shohre Yazdani, Reyhaneh Golabchian

Agricultural Biotechnology Research Institute of Iran (ABRII), Mahdasht Road, P.O. Box 31535-1897, Karaj, I.R. Iran

Abstract

Cotton (*Gossypium hirsutum* L.) is an important fiber crop in Iran, cultivated on 150000-200000 ha of land. In Iran the estimated loss due to the insect pest is more than 30%. Traditionally, pests are controlled by 10-12 times spraying per growing season of environmentally harmful chemical insecticides (e.g. endosulfan and/or methosystox). In order to produce transgenic cotton resistance to insects, hypocotyl explants were transformed with *Agrobacterium tumefaciens* strain LBA4404 harboring the recombinant binary vector pBI121 containing the *cry1Ab* gene under the control of CaMV 35S promoter. Neomycin phosphotransferase (*nptII*) gene was used as a selectable marker. Inoculated tissue sections were placed onto co-cultivation medium. Transformed calli were selected on MS medium containing 50 mg/l of kanamycin and 200 mg/l of cefotaxime. Plantlets were subsequently regenerated from putative transgenic calli. Polymerase chain reaction (PCR) and southern blot analysis were used to confirm the integration of *cry1Ab* and *nptII* transgenes into the plant genome. Western immunoblot analysis of proteins extracted from leaves of transgenic plants revealed the presence of an immunoreactive band with a molecular weight (MW) of approximately 67kDa in transgenic cotton lines using the anti-Cry1Ab polyclonal anti-serum. Homozygous T₂ plants (Line 61) for the *cry1Ab* gene showed significantly higher levels of insect resistance against *Heliothis armigera* larvae compared with the control plants. Transgenic plants are currently grown in the greenhouse and will be crossed with Iranian cotton breeding lines.

Keywords: *Agrobacterium tumefaciens*; *Bacillus thuringiensis*; Cotton; *Heliothis armigera*; Insect resistance; Genetic transformation; *cry1Ab*.

INTRODUCTION

Cotton (*Gossypium hirsutum* L.) is the world's most important source of natural fiber with approximate annual plantation of 35 million ha worldwide (Wilkins *et al.*, 2000). In recent years, genetic engineering of plants has facilitated the production of agronomically desirable crops that exhibit increased resistance to pests, herbicides, pathogens, and environmental stresses as well as enhanced quality and quantity. Cotton has attracted much interest in the field of gene transfer with the aim of introducing agronomically interesting new traits (Wilkins *et al.*, 2000; John and Keller, 1996). The level of losses due to insect damage is such that cotton protection represents approximately 24% of the global insecticide market (Chen *et al.*, 2002). Cotton Bollworm (*Heliothis armigera*) is one of the most important insect pests limiting crop yield under certain environmental conditions that include the cotton growing areas of Iran.

Cotton breeding for insect resistance has been limited by a lack of sufficient genetic variation in the existing germplasms. Therefore, efforts to improve productivity by genetic engineering of cotton plants are critical in enhancement of resistance to insect pests. The advent of genetic engineering approaches to insect resistance in crop plants now raises the possibil-

*Correspondence to: **Masoud Tohidfar**, Ph.D.
Tel: +98 261 2703536; Fax: +98 261 2704539
E-mail: gtohidfar@yahoo.com

ity of achieving high levels of resistance to bollworm in cotton. Lepidopteran insects are sensitive to many of the Cry1 and Cry2 proteins produced by different *Bacillus thuringiensis* strains (Hofte and Whiteley, 1989). Cry1Ab is among the proteins known to be toxic when incorporated into artificial diets supporting bollworm growth in culture. These proteins are characterized by their safety with respect to non-target insects, vertebrates, and biodegradability (Kuiper *et al.*, 2001).

In the year 2007, from 114.3 million ha of genetically engineered crops, 23.0 million hectares were devoted to *Bacillus thuringiensis* (Bt) crops and 14.1 million hectares to crops containing both insecticide (Bt) and herbicide tolerance traits. Biotech cotton occupies 15.1 million hectares equivalent to one third of the global area of cotton cultivation and 13.2% of the global biotech crop area (James, 2007). Several laboratories have been able to transfer synthetic *cry1Ab* and *cry1Ac* genes into plants and develop transgenic crop with enhanced resistance to insects. These include broccoli (Xiang *et al.*, 2000), rice (Ye *et al.*, 2000; Ghareyazi *et al.*, 1997), corn (Koziel *et al.*, 1993), potato (Davidson *et al.*, 2002), soybean (Walker, 2002) tobacco (Shi *et al.*, 1999) and cotton (Wu *et al.*, 2006; Guo *et al.*, 2003; Chen *et al.*, 2002; Perlak *et al.*, 1990). Due to worldwide cultivation of Bt transgenic cotton plants, there has been a considerable decrease in the use of chemical insecticides, and as a result, reductions in environmental pollution and operator exposure to toxins have been achieved (Bennett *et al.*, 2004). Bt cotton cultivation has increased dramatically in the recent years. For example in India, an area of approximately 3.8 million ha has been devoted to Bt cotton (James, 2007). As a result of Bt cotton cultivation in India, there has been a 78.8% increase in the due to yield and a 14.7% reduction in pesticide cost as compared to non-Bt cotton (APCoAB, 2006).

Among the advantages of this approach are: (1) the availability of several diverse mechanisms of resistance including crystal (Cry) proteins from the soil bacterium *B. thuringiensis* (Gould, 1996) and proteinase inhibitors from plants such as cowpea and soybean (Zhao *et al.*, 1998; Roush, 1994); (2) the ability to introduce one or several such genes directly into popular cultivars without the disadvantages associated with sexual hybridization; and (3) the availability of three different methods of cotton transformation, i.e.

biolistic transformation (Rajasekaran *et al.*, 2000), *Agrobacterium*-mediated transformation (Tohidfar *et al.*, 2005; Zapata *et al.*, 1998) and a combination of both methods (MaJeed *et al.*, 2000).

Cotton is a major cash crop in the North east of Iran. Cotton bollworm is an important pest insect and is considered as a major pest in the cotton growing areas of the Golestan province. As Iranian cotton varieties have low regeneration potential and the Coker variety responds very well to regeneration and gene transfer, most of the desirable genes are initially introduced into latter and then back crossed into other varieties. The objective of this study was to transform cotton var. Coker with a synthetic *cry1Ab* gene using the *Agrobacterium* system for enhancing resistance to Lepidopteran insects.

MATERIALS AND METHODS

Plasmid construction: A 1.8 kb *cry1Ab* gene from pGEM-4z (Kindly provided by Professor I. Altosaar, University of Ottawa, Canada) was subcloned into the *Bam*HI site of pBI121 (Clontech, USA) yielding pBI121-Cry1Ab. Gene orientation was verified by double restriction digestion (*Eco*RI and *Hind* III). The expression of the *cry1Ab* gene was under the control of the constitutive CaMV 35S promoter (Fig. 1). The plasmid was transferred into competent cells of *Agrobacterium tumefaciens* (strain LBA 4404) by the freeze-thaw method (An, 1987).

Plant material and transformation procedure: Seeds of *Gossypium hirsutum* var. Coker were provided by the Cotton Research Institute of Iran, Gorgan, Golestan province. Cotton hypocotyl sections (0.5 cm²) obtained from 7 to 10 days old sterile seedlings were dipped into *Agrobacterium* cell suspensions grown to the late log phase (OD_{600 nm} = 0.6-0.8). Explants were gently shaken in the bacterial suspension for 5 seconds to ensure contact of all hypocotyls edges with bacterial cells. The hypocotyl pieces were blot dried and placed on a Whatman No. 1 filter paper and were subsequently transferred to MS medium (Murashige and Skoog, 1962) co-cultivation medium followed by incubation for 2 days at 26 ±2°C in the dark (Tohidfar *et al.*, 2005). After co-culture, hypocotyl pieces were transferred to callus induction medium (MS1) composed of MS salts supplemented

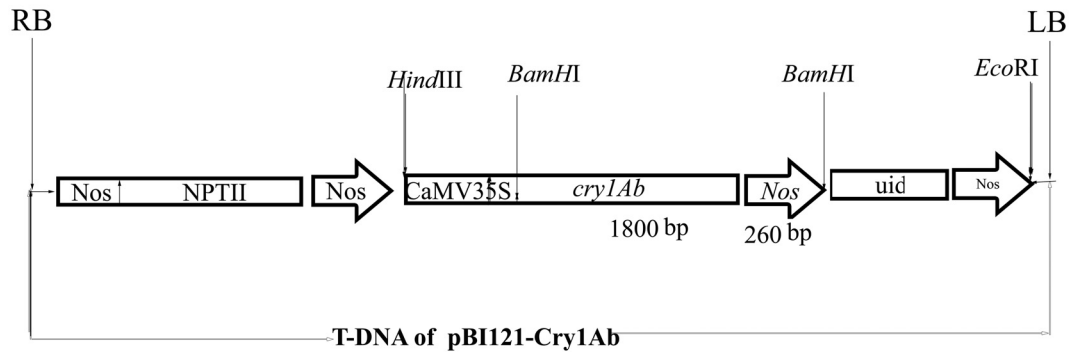

Figure 1. Chimeric gene map of the recombinant binary vector pBI121-Cry1Ab carrying the *cry1Ab* and *nptII* genes driven by the CaMV35S promoter. LB, left border; RB, right border; *nptII*, neomycin phosphotransferase; Nos-ter, nopaline synthase terminator; uid, b-glucuronidase.

with vitamin B5 and containing 0.75 g/l of $MgCl_2$, 30 g/l of glucose, 0.46 μM kinetin, 0.45 μM (2,4-Dichlorophenoxyacetic), pH 5.9, solidified with 0.2% (w/v) phytigel (Sigma, USA). Fifty mg/l of kanamycin and 200 mg/l of cefotaxime were also included for selection. Plates were incubated at 28°C with a 16-h photoperiod (90 $\mu mol/m^2/s$). After 3-4 weeks, calli were excised from original explants and transferred to fresh MS medium containing kanamycin. After another 2-3 weeks, calli were placed onto embryo maturation medium (MS2), composed of MS salts containing 0.75 g/l of $MgCl_2$, 1.9 g/l of KNO_3 , 0.25% (w/v), 30 g/l of glucose, pH 5.8 and supplemented with vitamin B5 and 25 g/l of kanamycin for selection. Mature embryos were picked up and transferred to embryo germination medium (MS3), composed of MS salts supplemented with vitamins B5, 0.45 μM zeatin, 30 g/l of sucrose and 25 mg/l of kanamycin (Zhang *et al.*, 2001; Kumar and Pental, 1998). Germinated somatic embryos were placed in 500 ml jars containing MS4 medium composed of MS salts supplemented with 100 mg/l of *myo*-inositol, 0.5 mg/l of thiamin-HCl, 0.5 mg/l of nicotinic acid, 0.5 mg/l of pyridoxine HCl, 3% (w/v) Sucrose and 0.15% (w/v) Gelrite (Sigma, USA), pH 5.7. Rooting medium did not contain kanamycin in order to allow formation of roots on the plantlets (Zapata *et al.*, 1998). Individual rooted plantlets were transferred to pots containing a (1:1 v/v) mixture of sterile soil and sand in plastic cups covered with polyethylene bags.

Transgenic cotton Lines were successfully self-pollinated, leading to the production of T_1 and T_2 seeds. Since the aim of this investigation was to produce homozygous pure lines, at least in the T_2 and later

generations, analysis of T_1 lines was not performed but the T_1 and T_2 plants were self-crossed and subjected to molecular analysis.

Polymerase chain reaction (PCR): PCR was carried out using specific primer pairs to amplify the *nptII*, and *cry1Ab* transgenes from transgenic cotton plants. The sequences of the primer pairs used in this assay were as follows: *nptII* 1: 5'-GAA CAA GAT GGA TTG CAC GC-3', *nptII* 2: 5'-GAA GAA CTC GTC AAG AAC GC-3', and *cry1Ab* F: 5'-AGG AAG TTC ATT CAT TTG CAG-3' *cry1Ab* R: 5'-TAA CTT CGG CAG GCA CAA AC-3'.

Genomic DNA was extracted and purified from immature leaves based on the protocol of Li *et al.* (2001). PCR was performed in a total reaction mixture volume of 25 μl consisting of 1X reaction buffer, 15 ng of DNA template, 1.5 mM $MgCl_2$, 1 mM of each of the dNTPs, 60 ng of each primer and one unit of *Taq* DNA polymerase (Cinagen Co., Iran).

PCR was carried out in a thermal cycler using the following conditions: initial denaturation at 94°C for 4 min followed by 35 cycles of denaturation at 94°C for 1 min, annealing at 55°C (for the *nptII*) and 60°C (for the *cry1Ab* gene) for 1 min, extension at 72°C for 3 min, followed by a final extension at 72°C for 5 min. Amplified DNA fragments were electrophoresed on 1.0% (w/v) agarose gel and visualized by ethidium bromide staining under ultraviolet (UV) light.

Southern blot hybridization: Fifty μg of DNA extracted from young leaves was completely digested with *Bam*HI and *Eco*RI at 37°C, overnight. Digested DNA fragments were separated on 0.8% (w/v) agarose

gels at 30 V for 8 h. DNA was transferred onto a nylon membrane (Hybond N⁺, Amersham, UK) by capillary blotting. Coding sequence of the *cry1Ab* gene (*Bam*HI fragment ~2.0 kb) was labeled with the DIG DNA labeling kit (Roche) and used as a probe. Detection was carried out using the DIG Detection Kit and according to the manufacturer's instructions (Roche, Germany).

Western blot analysis: Segments of leaves of transgenic and control plants were ground to a fine powder with a mortar and pestle in liquid nitrogen. Soluble proteins were extracted with 1 ml of extraction buffer [40% (w/v), SDS, 5% (v/v) 2-mercaptoethanol, 20% (v/v) glycerol, 68 mM Tris- HCl (pH 6.8)]. Ten µg of protein from each sample was fractionated by 13% (w/v) SDS-polyacrylamide gel electrophoresis, as described by Laemmli (1970). Western immunoblot analysis of the *cry1Ab* gene was performed as described by Ghareyazie *et al.* (1997). After transferring the proteins onto a Hybond-C membrane (Amersham, England) by a semi-dry trans-electroblotter (Sigma Co., UK), the membrane was probed with the anti-Cry1Ab anti-serum (1:2000 v/v) (a gift from Prof. Altossar, University of Ottawa, KIN 6N5 Canada). The goat-anti rabbit IgG alkaline phosphatase conjugate (1:2000 v/v) (Gibco, USA) was used as a secondary antibody. Total soluble protein was measured using the Bradford method (1976).

Insect Bioassays: Adult cotton bollworms (*Heliothis armigera*) were collected from the cotton fields of Gorgan, Golestan province. The moths were caged on cotton plants. Egg masses were collected from the plants and held in plastic cups. One day prior to the expected egg hatch, the egg masses were placed in vials with artificial insect diets to provide food for the early hatching larvae. Neonate larvae were collected from the vials and used in the bioassay, in the entomology testing chamber. The temperature in this chamber was maintained at 25-28°C and 85% humidity.

Prior to the blooming stage, fully expanded young leaves on the top of the transgenic cotton plants were used for the cut leaf assay. This experiment was performed in 20 cm Petri dishes in three replications. The leaves were infested with five larvae and the plates were sealed with Parafilm and were kept in 25-27°C in entomology testing chamber. The numbers of live and dead insects were recorded 3 and 7 days after infesta-

tion, and the weight of live insects were measured on the 7th day. The mortality and degree of the leaf damage was measured according to a previously described method (Gallie *et al.*, 1988).

Mortality% = Number of dead larva/total Number of larva placed in Petridish × 100. Degree of leaf damage: little or no damage; 1: mildly damaged (10-20%); 2: moderately damaged (20-40%); 3: severely damaged (40-70%); 4: completely destroyed (70-100%).

Transgenic cotton lines were successfully self-pollinated and T₁ and T₂ seeds were produced as a result. Twenty T₁ seeds of each PCR- positive T₀ plant showing a higher resistance against insect pests with mortality higher than 80%, were collected for inheritance analysis and selection of the homozygous positive plants.

RESULTS

Transformation and selection: Kanamycin- resistant microcalli (0.5 mm in diameter) emerged at the wounded sites of hypocotyl segments co-cultivated with *Agrobacterium* 3 weeks after incubation on MS medium (Fig. 2A), while no callus was obtained from the untransformed explants. The transformed calli were placed and maintained on the embryogenic selection medium. The calli produced light yellow-colored granular embryogenic structure, which eventually developed into somatic embryos (Fig. 2B). Germinated embryos were transferred to Jars on MS4 medium.

The plantlets were regenerated after two to three months (Fig. 2C). Twelve putative independent transgenic plants with well developed leaves and root systems were transferred to soil and left to flower and set seeds under green house conditions (Fig. 2D).

Integration of the *cry1A(b)* gene: Twelve randomly selected T₀ plants exhibiting some degree of kanamycin resistance were analyzed by PCR. Ten of these plants yielded a single DNA fragment of 785 bp for the *nptII* gene (Fig. 3). All 10 transformants were also positive for the *cry1Ab* gene, as indicated by the amplification of the predicted 1.8 kb internal fragment of the *cry1Ab* gene. Untransformed cotton plants were negative for both *nptII* and *cry1Ab* genes (Fig. 4a). Transgenic cotton lines were successfully self-pollinated, thus setting seeds. Similar PCR products obtained from the T₀ plants were also amplified in their T₁ progenies (Fig. 4b).

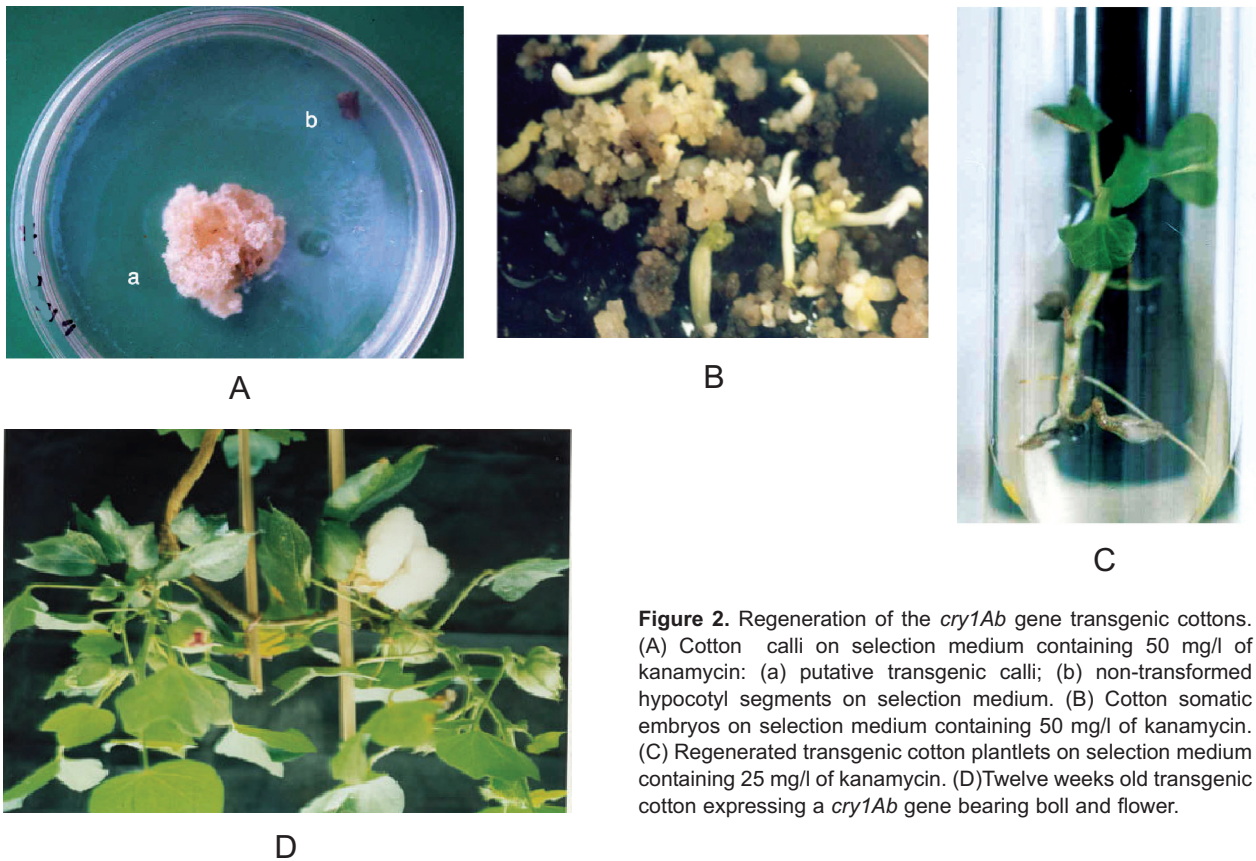

Figure 2. Regeneration of the *cry1Ab* gene transgenic cottons. (A) Cotton calli on selection medium containing 50 mg/l of kanamycin: (a) putative transgenic calli; (b) non-transformed hypocotyl segments on selection medium. (B) Cotton somatic embryos on selection medium containing 50 mg/l of kanamycin. (C) Regenerated transgenic cotton plantlets on selection medium containing 25 mg/l of kanamycin. (D) Twelve weeks old transgenic cotton expressing a *cry1Ab* gene bearing boll and flower.

Figure 5 shows southern blot analysis of T₀ and T₁ transgenic lines (31, 57 and 61). Analysis of DNA blotting established that plants 31, 57 and 61 were independent transformants. The 600 bp PCR product of the coding sequence of the *cry1Ab* gene was used as probe. Hybridization to undigested DNA was occurring exclusively at high molecular weights, indicating the integration of the gene into the cotton genome. When the DNA was digested with *Bam*HI, most of the

hybridization was to an expected fragment of 2.0 kb that included the whole coding sequence of *cry1Ab* gene and the *nos* terminator. This result shows that at least one intact copy of the integrated *cry1Ab* gene is present (Fig. 5a). When *Eco*RI digested DNA was hybridized to the probe, only one band with different sizes (~4.5 kb for line 31, larger than 12.0 kb for line 57 and ~3 kb for line 61) was detected in each of the different transgenic lines examined. Since there is only one *Eco*RI site in the T-DNA, this result indicates the presence of only one single copy of the transgene in each of the three independent transgenic events (Figs. 5b and 5c). No hybridization signal could be detected for the DNA extracted from the untransformed plants.

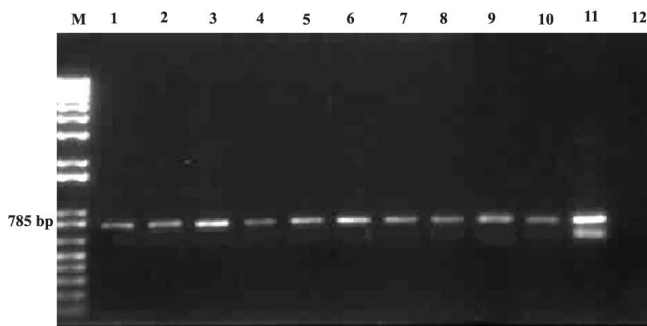

Figure 3. PCR analysis of DNA isolated from leaves of transformed cotton using primer pairs specific for amplification of the 785 bp *nptII* gene in agarose gel. Lanes 1-10, DNA from putative transgenic cotton lines; lane 11, DNA from pBI121-*cry1Ab*; lane 12, DNA from untransformed cotton; M, 1.0 kb plus DNA ladder (Gibco BRL, USA).

Expression of the *cry1A (b)* gene: For technical reasons immunoblot analysis was not carried out for the T₀ generation. Immunoblot analysis of the T₂ transgenic plants (lines 61 and 57) and the untransformed control showed high levels of Cry1Ab protein production in both plants 61 and 57 (Fig. 6). The size of the Cry1Ab protein accumulating in leaves of T₂ transgenic plants (lines 61 and 57) was 67 kDa.

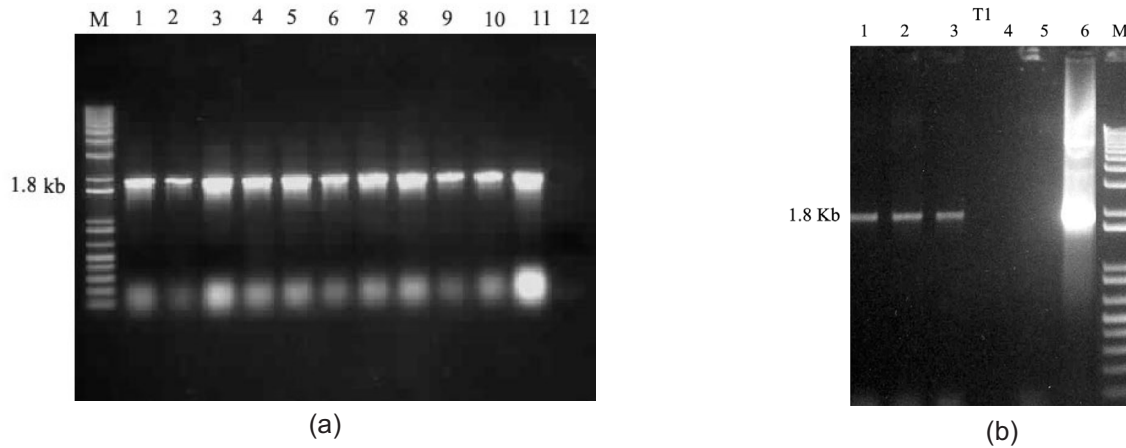

Figure 4. PCR analysis of DNA isolated from leaves of transformed cotton using primer pairs specific for amplification of the 8 kb *cry1Ab* gene on agarose gel. (a) T_0 progeny. Lanes 1-10, DNA from putative transgenic cotton lines; lane 11, DNA from pBI121-Cry1Ab; lane 12, DNA from untransformed cotton; M, 1.0 kb plus DNA ladder. (b) T_1 progeny selected from the T_0 transformant. Lanes 1-3, DNA from transgenic cotton lines; lane 4, DNA from untransformed cotton; lane 5, sterile water; lane 6, DNA from pBI121-Cry1Ab; M, 1.0 kb plus DNA ladder.

Untransformed control did not show any positive signal for Cry1Ab protein.

Bioassay of T_0 plants with cotton bollworm:

Bioassay was carried out on transgenic cotton plants by using larvae of the cotton bollworm. After being infested for 7 days, lines 61 and 57 proved to be the plants on which all recovered larvae were dead. The

dead larvae possessed black head capsule and pronotum, characteristic of the first instar. The larvae recovered from untransformed control plants were alive and relatively larger. They had developed into the second instar and caused considerable damage.

Bioassay of T_2 plants with cotton bollworm:

Transgenic cotton lines were successfully self-pollinated.

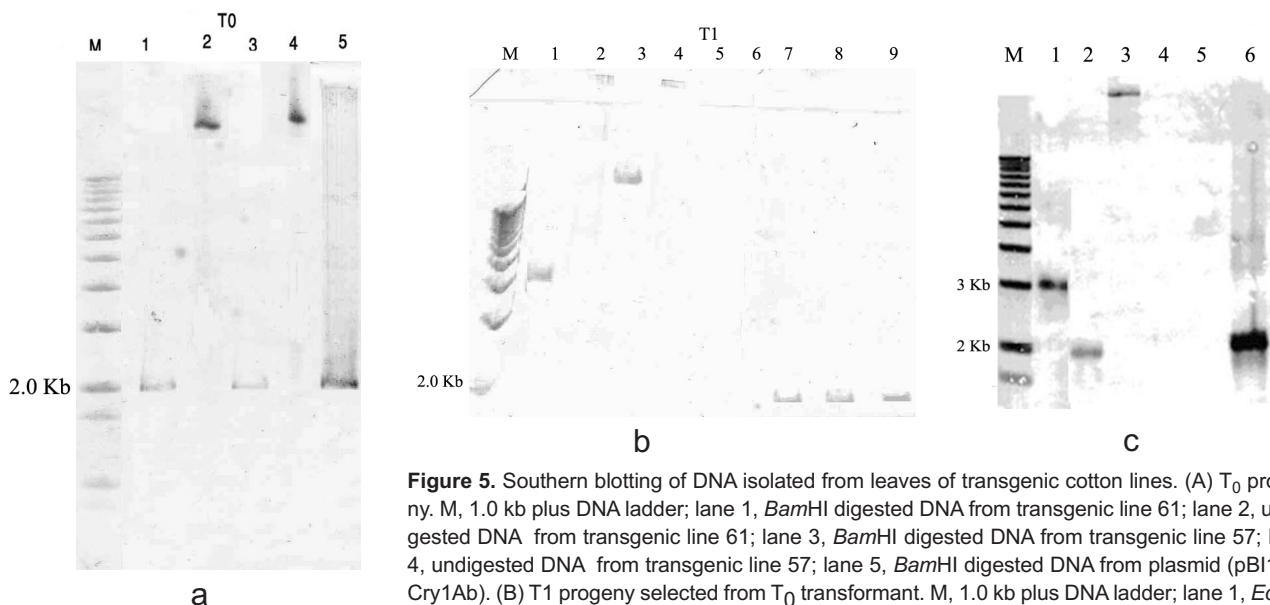

Figure 5. Southern blotting of DNA isolated from leaves of transgenic cotton lines. (A) T_0 progeny. M, 1.0 kb plus DNA ladder; lane 1, *Bam*HI digested DNA from transgenic line 61; lane 2, undigested DNA from transgenic line 61; lane 3, *Bam*HI digested DNA from transgenic line 57; lane 4, undigested DNA from transgenic line 57; lane 5, *Bam*HI digested DNA from plasmid (pBI121-Cry1Ab). (B) T_1 progeny selected from T_0 transformant. M, 1.0 kb plus DNA ladder; lane 1, *Eco*RI digested DNA from transgenic line 31; lane 2, undigested DNA from transgenic line 31; lane 3, *Eco*RI digested DNA from transgenic line 57; lane 4, undigested DNA from transgenic line 57; lane 5, *Bam*HI digested DNA from untransformed cotton; lane 6, *Eco*RI digested DNA from untransformed cotton; lane 7, *Bam*HI digested DNA from transgenic line 31; lane 8, *Bam*HI digested DNA from transgenic line 57; lane 9, *Bam*HI digested DNA from plasmid (pBI121-Cry1Ab). (C) T_1 progeny selected from T_0 transformant. M, 1.0 kb plus DNA ladder; lane 1, *Eco*RI digested DNA from transgenic line 61; lane 2, *Bam*HI digested DNA from transgenic line 61; lane 3, undigested DNA from transgenic line 61; lane 4, *Eco*RI digested DNA from untransformed cotton; lane 5, *Bam*HI digested DNA from untransformed cotton; lane 6, *Bam*HI digested DNA from plasmid (pBI121-Cry1Ab).

Untransformed control did not show any positive signal for Cry1Ab protein.

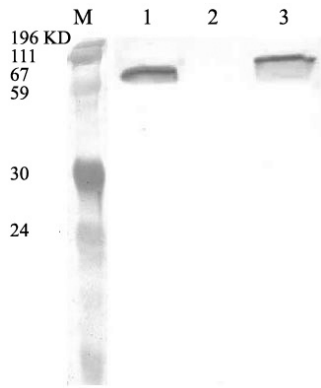

Figure 6. Immunoblot analysis of cotton lines for detection of *cry1Ab* gene expression. Protein was extracted from T₂ transgenic lines and a control plant. M, prestained standard markers in kDa; Lane 1, protein extracted from transgenic line 61; lane 2, protein extracted from untransformed cotton; lane 3, protein extracted from transgenic line 57.

nated, thus setting seeds. The seeds were indistinguishable in appearance from non-transgenic seeds.

Table 1 shows the development (mortality and degrees of damage) of larvae fed on the transgenic lines. The plants were infested with first instar cotton bollworm larvae and dissected 7 days after infestation.

All larvae recovered from the Cry1Ab-positive T₂ plant (plant 61) were dead and had not progressed beyond the first instar (Fig. 7). Progeny analysis by PCR showed that the T₂ line 61 was homozygous for the *cry1Ab* gene and the T₁ lines 31 and 57 were hemizygous for the *cry1Ab* gene (data not shown). By contrast, all larvae recovered from the control plants were alive and had progressed to the second or third instar (Fig. 8). The majority of larvae on the Cry1Ab positive plants was not recovered and is presumed to have died and decomposed or to have dispersed from the plants. In contrast, all recovered larvae fed on non-transgenic control plants were alive.

As judged by the damage rate and mortality of the recovered larvae we conclude that line 61 was a transgenic line which could be further studied for commercial applications since they were significantly resistant against the studied insect pest.

DISCUSSION

Transgenic cotton plants using the transformation system as described previously (Zhang *et al.*, 2001;

Table 1. Part of the data of the insect bioassay on T₂ transgenic cottons.

Transgenic line	Mortality (%)		Leaf damage
	3 DAI*	7 DAI	
61	100	100	0
57	80	80	0.7
Control	19	19	2.5

* Days After Infestation



Figure 7. Bioassay using bollworm. (A) After 7 days on leaves of T₂ transgenic line 61, first larvae were all dead. No visible damage, no live larvae recovered. (B) After 7 days on leaves of non-transgenic control plants, larvae were alive and progressed to second instar. Extensive visible damage was observed and no dead larvae were recovered.

Kumar and Pental, 1998; Zapata *et al.*, 1998) were readily obtained in this investigation. Also, in this study, it was observed that the presence of kanamycin was disadvantageous to rooting, so the use of antibiotics was abolished during rooting and plant regeneration. Rapid callus initiation (on MS medium containing 0.46 μ M kinetin and 0.4 μ M 2,4-Dichlorophenoxyacetic) was critical for the recovery of a high number of transformed microcalli at the periphery of the inoculated tissues. This could be due to a better recovery of transformed cells on this medium and high competency of dividing cells for transformation with *A. tumefaciens*, or both (Firoozabady and Galbraith, 1984 and 1983).

In this research, by using the hypocotyl as an explant for inoculation (Firoozabady *et al.*, 1987), only a few untransformed calli proliferated rapidly. These tissues were highly chimeric due to lack of complete contact between explants and kanamycin containing medium. Excision of calli from the explants was essential for promoting growth of calli and avoiding *Agrobacterium* contamination. Small sized calli had a lower rate of survival. This situation is believed to be similar to the requirement for a critical minimum cell density, as reported for the growth of cells or protoplasts (Shneyour *et al.*, 1984). Glucose was used as a sole carbon source for callus induction and embryo maturation since sucrose encouraged production of phenolics by cotton explants. Using rooting powder along with liquid MS

medium was found to be more effective for root induction. Of the 12 putative the T_0 plants infected by *Agrobacterium* at different periods and analyzed by PCR, 10 were found to be positive, indicating that the rate of escape occurred during the selection procedure of our experiment.

Thirty transgenic T_0 plants were produced from 50 different inoculations (data not shown). Of these, two lines were analyzed in detail and shown that they were independent events and were significantly more resistant against cotton bollworm. The transgenic lines 61 and 57 were normal in appearance and fertile, but a few of the other independent events were male sterile (data not shown).

Majority of lines that gave positive results for PCR analysis were further confirmed by southern hybridization (data not shown). In most of the analyzed plants, only one copy of the transgene was integrated into the cotton genome. The different sizes of hybridization signals also indicated that they resulted from the stable T-DNA integration into the cotton genome and not from endophytic *Agrobacterium* contamination. Lines 61 and 57 had integrated one copy of the *cry1Ab* gene into their genome. However, presence of the expected hybridization signals in the majority of the transformed plants showed that the probed gene and coding sequence of *cry1Ab* remained intact when integrated into the cotton genome.

Lines 61 and 57 were also the plants that produced sufficient Cry1Ab protein to be detected by immunoblots. Immunoreaction of the protein blot with the Cry1Ab antiserum produced a specific band with a molecular weight of 67 KDa.

Feeding assays with T_0 plants from two independent transformants confirmed that the Cry1Ab protein produced in the transgenic Line 61 was highly toxic to cotton bollworm. The larvae began to die 1 or 2 days after feeding on the transgenic leaf tissues. A mortality of 100% was reached 4-5 days after infestation. The Cry1Ab-positive T_1 plants showed enhanced resistance to cotton bollworm. Differences in larval mortality and development between the Cry1Ab-positive and control plants were generally apparent 3-4 days after infestation.

Taken together, these observations suggest that the toxin levels in cotton line 61 (T_2 generation) are sufficient to confer a high degree of cotton bollworm resistance. Transgenic plants are currently being grown in

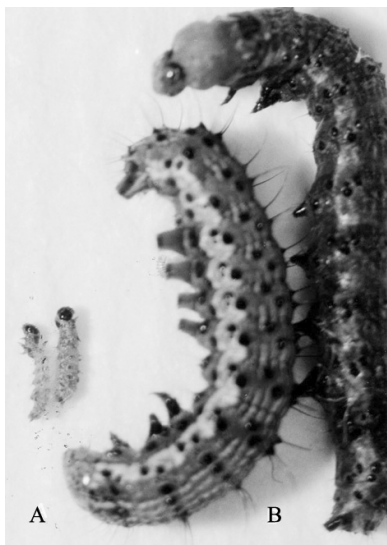

Figure 8. Bioassay using bollworm (*Heliothis armigera*). (A) Larvae recovered from transgenic line 61. (B) Larvae recovered from non-transformed cotton.

the greenhouse and will be crossed with the Iranian cotton cultivars for the purpose of introgression of the *cry1Ab* gene.

Acknowledgments

We wish to thank Prof. Illimar Altossar, for providing us the anti-Cry1Ab anti-serum. The pGEM-4z plasmid (containing the *cry1Ab* gene) was kindly provided by the Department of Biochemistry, University of Ottawa, KIN 6N5 Canada, for the purpose of sole scientific research.

References

- An G (1987). Binary TI vectors for plant transformation and promoter analysis. *Methods Enzymol.* 153: 292-293.
- Asia-Pacific Consortium on Agricultural Biotechnology (2006). *Bt cotton in India- A status report*. Asia-Pacific Consortium on Agricultural Biotechnology, New Delhi, India. PP. 10-20.
- Bennett R, Ismael Y, Kambhampati U, Morse S (2004). Economic impact of genetically modified cotton in India. *AgBioForum.* 7: 96-100.
- Bradford MM (1976). A rapid and sensitive method for the quantification of microgram quantities of protein utilizing the principle of protein-dye binding. *Anal Biochem.* 72: 248-254.
- Chen WX, Xiao GF, Zhu Z (2002). Obtaining high pest-resistant transgenic upland cotton cultivars carrying *cry1Ac3* gene driven by chimeric OM promoter. *Acta Botanica Sinica.* 44: 963-970.
- Davidson MM, Jacobs JM E, Reader JK, Butler RC, Frater CM, Markwick NP, Wratten SD, Conner AJ(2002). Development and evaluation of potatoes transgenic for a *cry1Ac9* gene conferring resistance to potato tuber moth. *J Am Soc Hort Sci.* 127: 590-596.
- Firoozabady E, Galbraith DW (1983). The effects of cell wall and cell cycle on crown gall umorigenesis. *HortScience.* 18: 441-449.
- Firoozabady E, Galbraith DW (1984). Presence of a plant cell wall is not required for transformation of *Nicotiana* by *Agrobacterium tumefaciens*. *Plant Cell Tiss Org Cult.* 3: 175-188.
- Firoozabady E, DeBoer DL, Merlo D, Halk E, Amerson L, Rashka KE, Murray EE (1987). Transformation of cotton (*Gossypium hirsutum* L.) by *Agrobacterium tumefaciens* and regeneration of transgenic plants. *Plant Mol Biol.* 10: 105-116.
- Gallie DR, Walbot V, Hershey JW (1988). The ribosomal fraction mediated the translational enhancement associated with the 5'-leader of tobacco mosaic virus. *Nucleic Acids Res.* 16: 8675-8694.
- Ghareyazie B, Alinia F, Menguito CA, Rubia LG, Palma JM, Liwanag EA, Cohen MB, KhushGS, Bennett J (1997). Enhanced resistance to two stem borers in an aromatic rice containing a synthetic *cryIA(b)* gene. *Mol Breed.* 3: 401-414.
- Gould F (1996). Deploying pesticidal engineering crops in developing countries. In: *Biotechnology and integrated pest management*, Persley GJ (ed), UK, PP: 264-293.
- Guo HN, Wu JH, Chen XY, Luo XL, Lur SHI, YJ, Qin HM, Xiao JL, Tian YC (2003). Cotton plants transformed with the activated chimeric *cry1Ac* and *API-B* genes. *Acta Botanica Sinica.* 45: 108-113.
- James C (2007). *Global Status of Commercialized Biotech/GM Crops*. International Service for the Acquisition of Agri-biotech Applications, Ithaca, New York. PP. 1-16.
- Höfte H, Whiteley HR (1989). Insecticidal crystal proteins of *Bacillus thuringiensis*. *Microbiol Rev.* 53: 242-255.
- John ME, Keller G (1996). Metabolic pathway for engineering cotton: iosynthesis of polyhydroxybutyrate in fiber cells. *Proc Natl Acad Sci.* 93: 12768-12773.
- Kozziel MG, Beland GL, Bowman C, Carozzi NB, Crenchaw R, Crossland L (1993). Field performance of elite transgenic maize plants expressing an insecticidal protein derived from *Bacillus thuringiensis*. *Bio/ Technology.* 11: 194-200.
- Kuiper HA, Kleter GA, Noteborn HP, Kok EJ (2001). Assessment of the food safety issues related to genetically modified foods. *Plant Journal.* 27: 503-528.
- Kumar S, Pental D (1998). Regeneration of Indian cotton variety MCU-5 through somatic embryogenesis. *Curr Sci.* 74: 538-540.
- Laemmli UK (1970). Cleavage of structural proteins during the assembly of the head of bacteriophage T4. *Nature* 227: 680-685.
- Li H, Jinhua L, Hemphill JK, Wang JT, Gould J (2001). A rapid and high yielding DNA miniprep for cotton (*Gossypium* spp.). *Plant Mol Biol Rep.* 19: 183-183.
- Majeed A, Husmain T, Riazuddin(2000). Transformation of virus-resistant genotype of *Gossypium hirsutum* L. with pesticidal gene. *Plant Biotechnol.* 17: 105-110.
- Murashige T, Skoog F (1962). A revised medium for rapid growth and bioassays with tobacco tissue cultures. *Plant Physiol.* 15: 472-497.
- Perlak FJ, Deaton RW, Armstrong TA, Fuchs RL, Sims SR, Greenplate JT, Fischhoff DA (1990). Insect resistant cotton plants. *Bio/ Technology.* 8: 939-943.
- Rajasekaran K, Hudspeth RL, Cary JW, Anderson DM, Jacks TJ, Stromberg K, Cleveland TE (2000). High-frequency stable transformation of cotton (*Gossypium hirsutum* L.) by particle bombardment of embryogenic cell suspension cultures. *Plant Cell Rep.* 19: 539-545.
- Roush R (1994). Aust. Cotton grower. 15: 17-20.
- Sambrook J, Russell DW (2001). *Molecular Cloning: A Laboratory Manual*. Cold Spring Harbor Laboratory Press, NY. PP. 6.39-6.64.
- Shi CL, Zhu Z, Xiao GF, Altosaar I, Feng PZ (1999). Construction of a high efficient Bt gene expression structure and the study of its expression behavior in transgenic tobacco. *Chin J Biotech.* 15: 422-427.
- Shneyour Y, Zelcer A, Izhar S, Backman JS (1984). A simple feeder layer technique for the plating of cells and protoplasts at low density. *Plant Sci Lett.* 33: 293-302.
- Tohidfar M, Ghareyazie B, Mohammadi M (2005). *Agrobacterium*-mediated transformation of cotton using a chitinase gene. *Plant Cell Tissue and Organ Culture.* 83: 83-

96.

- Walker D, Boerma H R, All J, Parrott W (2002). Combining *cry1Ac* with QTL alleles from PI 229358 to improve soybean resistance to lepidopteran pests. *Mol Breed.* 9: 43-51.
- Wilkins TA, Rajasekaran K, Anderson M (2000). Cotton biotechnology. *Crit. Rev. Plant Sci.* 19: 511-550.
- Wu J, Luo X, Guo H, Xiao J, Tian Y (2006). Transgenic cotton, expressing *Amaranthus caudatus* agglutinin, confers enhanced resistance to aphids. *Plant Breeding.* 125: 390-394.
- Xiang Y, Wong WKR, Ma MC, Wong RSC (2000). *Agrobacterium* mediated transformation of *Brassica campestris* ssp. *parachinensis* with synthetic *Bacillus thuringiensis cry1A(b)* and *cry1A(c)* genes. *Plant Cell Rep.* 19: 251-256.
- Ye GY, Shu QY, Cui HR, Hu C, Gao MW, Xia YW, Cheng X, Altosaar I (2000). A leaf-section bioassay for evaluating rice stem borer resistance in transgenic rice containing a synthetic *cry1Ab* gene from *Bacillus thuringiensis* Berliner. *Bull Entomol Res.* 90: 179-182.
- Zapata CS, Park H, EI-Zik KM & Smith RH (1998). Transformation of a Texas cotton cultivar by using *Agrobacterium* and the shoot apex. *Theor Appl Genet.* 98: 252-256.
- Zhang BH, Feng R, Liu F, Wang Q (2001). High frequency somatic embryogenesis and plant regeneration of an elite Chinese cotton variety. *Bot Bull Acad Sin.* 42: 9-16.
- Zhao JZ, Zhao KJ, Lu MG, Fan XL, Guo SD (1998). *Sci Agric Sin.* 31: 1-6.